

New product

IMEC introduces Castor, an ultra-low-power high-voltage driver IC targeted for the emerging non-volatile reflective LCD market, specifically bi-stable Cholesteric LCD's. This is the first commercial product driver featuring the fast dynamic driving scheme.

Features

- Drives bistable and multistable displays
- Black-White or Gray-Scale
- Compatible with conventional and dynamic driving schemes for Cholesteric LCD (ChLCD)
- Usable as row or column driver
- Gnd to 100V drive voltage range
- 1.2mA minimum Source/Sink
- Cascadable
- Ultra low power consumption
- 3V logic supply
- 2 different operation modes:
 - 1st mode: - 80 outputs with each output
 - 4 HV levels + GND
 - 4 bit PWM/AM
 - 2nd mode: - 40 outputs with each output
 - 8 HV levels + GND
 - 8 bit PWM/AM
- Slim 9.5 X 3 mm² size, 110µm output pitch

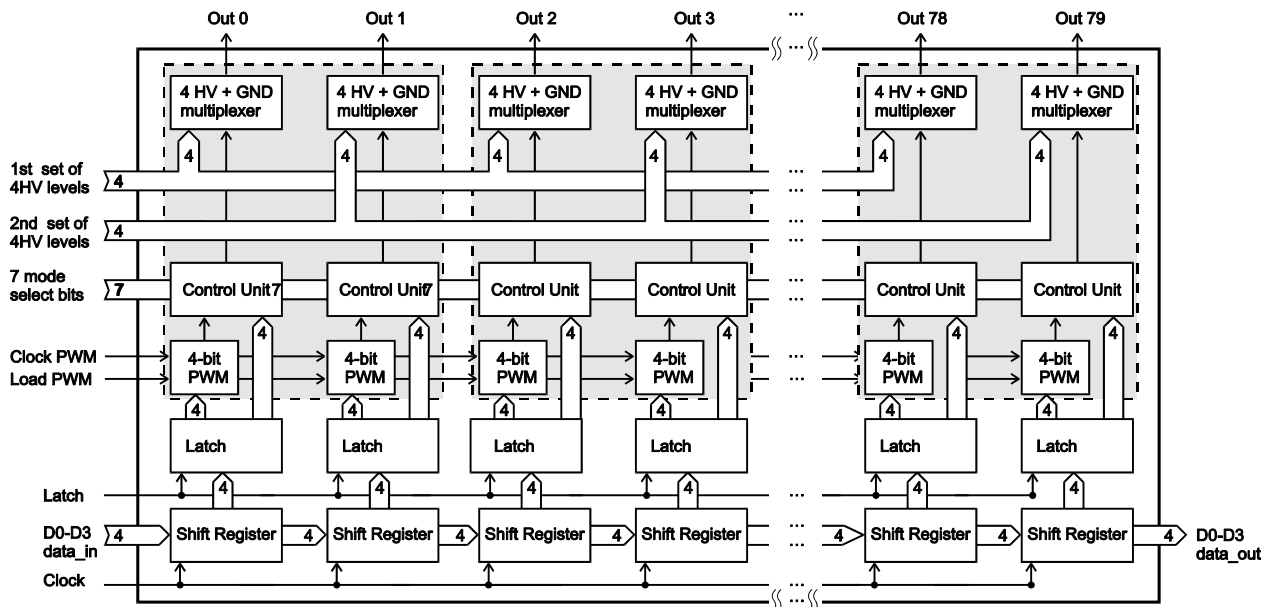

Description

Castor is an 80-output, 100V high voltage, ultra-low-power driver IC, suited for non-volatile displays. It can be used as a row or column driver and can be cascaded for arbitrary display resolution. Each output is a high-voltage analogue multiplexing circuit selecting one out of 4 high voltage levels or a gnd level. In a special operating mode, 2 consecutive outputs can be combined together, resulting in an output with 8 high voltage levels + gnd level. For this reason, there are two sets of 4 high voltage level inputs. This allows among others the implementation of dynamic driving schemes for bistable cholesteric texture displays. The response time is smaller than 10µs and all outputs are short-circuit protected. The level shifters in the output stages employ the 'dynamic charge control' technique, where energy is only consumed during a state transition, as is the case in low-voltage CMOS. This avoids the continuous power dissipation during the image update seen in traditional high-voltage drivers and can result in dramatic power savings. The selected level in each output depends on the output of the 4-bit wide latch and the common control bits. In column mode, the output of the 4-bit wide latch can be used as a preload for a 4 bit binary down counter allowing PWM and AM gray scales. If two consecutive outputs are combined, 8 bit PWM or AM is possible. Proper operation of the logic allows among others driving conventional and dynamic cholesteric driving schemes, charge recycling and global display reset. Both unipolar and bipolar driving schemes are possible.

CASTOR



IMPORTANT NOTICE

"Preliminary" product information describes products that are ready for production, but for which full characterization data is not yet available. "Advance" product information describes products that are in development and subject to development changes. IMEC vzw believes that the information contained in this document is accurate and reliable. However, the information is subject to change without notice and is provided "AS IS" without warranty of any kind (Express or implied). You are advised to obtain the latest version of relevant information to verify, before placing orders, that information being relied on is current and complete. All products are sold subject to the terms and conditions of sale supplied at the time of order acknowledgement, including those pertaining to warranty, patent infringement, and limitation of liability. No responsibility is assumed by IMEC vzw for the use of this information, including use of this information as the basis for manufacture or sale of any items, or for infringement of patents or other rights of third parties. This document is the property of IMEC vzw and by furnishing this information, IMEC vzw grants no license, express or implied under any patents, mask work rights, copyrights, trademarks, trade secrets or other intellectual property rights. IMEC vzw owns the copyrights of the information contained herein and gives consent for copies to be made of the information only for use within your organization with respect to "IMEC information". This consent does not extend to other copying such as copying for general distribution, advertising or promotional purposes, or for creating any work for release.

IMEC vzw shall not be held liable for any damages, which may result out of the use of IMEC information. Use of IMEC information implies the acceptance by user of all responsibility and liability connected with the use of IMEC information.