

**A**dvanced  
**L**ow  
**P**ower,  
**H**igh-Voltage  
**A**ASIC for the  
**D**evelopment of  
**D**isplay  
**D**riving schemes

## Features

- 1/16 VGA output
- gnd to 100V line drive
- 4-bit gray levels (PWM, AM)
- 12 integrated 2.5V → 100V generators
- Ultra low power consumption
- 3 to 5V power supply
- Maximum flexibility in waveform synthesis

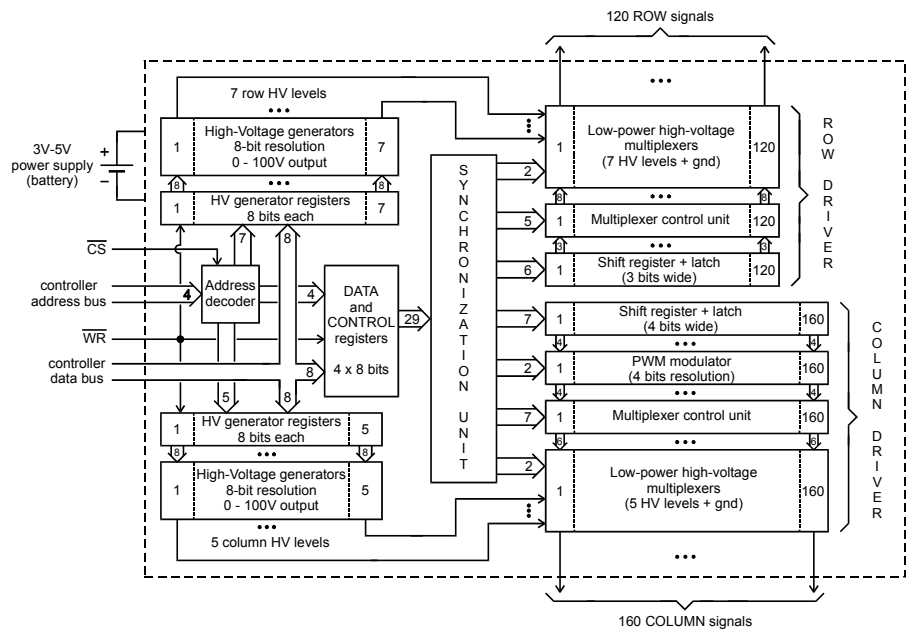

## Description

High-Voltage driver chip with integrated high-voltage generators. Combines 100 V driving capability with extremely low power consumption from a 3V battery (e.g. a total power dissipation below 20mW for a 1/16 VGA Cholesteric LCD during scanning). Intended for developing and prototyping different types of high-voltage display systems, it features maximum flexibility in waveform synthesis in order to achieve maximum optical performance at minimum power consumption.

## Low power, High-Voltage Multiplexer drivers

The row (column) driver consists of a 120 (160)-stage shift registers plus latch, a logical control unit and 120 (160) high-voltage multiplexers (0-100V) selecting one of 7 (5) high-voltage levels or ground. The column driver also contains a 4-bit PWM modulator for producing PWM gray shades. The level shifters employ the ‘dynamic charge control’ technique, where energy (6nJ @100V) is only consumed during the transition of each switch, avoiding the continuous power dissipation in traditional level shifters. The voltage switches can source 4mA and sink 1.5mA, the ground switch can sink 12mA. Response time is 2µs. All outputs are short-circuit protected.

## Integrated High-Voltage generators

The HV levels can be externally applied or internally generated by 7 row and 5 column generators from a 3V battery. All generators are digitally programmable between 2.5V and 108V with 8 bit resolution (0.43V).

- Non linearity: < 1 LSB
- Max. O/P current: 2mA @ 25V, 200µA @100V
- Efficiency: 60% @ 25V, 35% @100V
- Ripple: < 1LSB

## Interface and control

All functions of the chip are controlled by 16 internal registers (12 for the generators and 4 for the row and column drivers). Communication between these internal registers and an external µcontroller is established through standard data and address bus architecture.

## Physical features

19315µm X 18543µm naked die, 366pins @ 126µm pitch. Also available on 9X6cm<sup>2</sup> pcb with 600µm pitch fast-speed smd connector.

## Maximum flexibility in waveform synthesis

- Arbitrary waveform generation
- Low-speed conventional addressing schemes
- High-speed multi-phase dynamic driving schemes
- Bipolar or unipolar driver operation
- 4-bits PWM gray levels
- Full-color operation
- Charge recycling
- Global display reset

## Waveform Development Tool

The Alpha3D ASIC is specially designed for the “Waveform Development Tool”, a GUI-based waveform generator for developing and prototyping different types of high-voltage display systems.

---

# Alpha3D

---



## IMPORTANT NOTICE

"Preliminary" product information describes products that are ready for production, but for which full characterization data is not yet available. "Advance" product information describes products that are in development and subject to development changes. IMEC vzw believes that the information contained in this document is accurate and reliable. However, the information is subject to change without notice and is provided "AS IS" without warranty of any kind (Express or implied). You are advised to obtain the latest version of relevant information to verify, before placing orders, that information being relied on is current and complete. All products are sold subject to the terms and conditions of sale supplied at the time of order acknowledgement, including those pertaining to warranty, patent infringement, and limitation of liability. No responsibility is assumed by IMEC vzw for the use of this information, including use of this information as the basis for manufacture or sale of any items, or for infringement of patents or other rights of third parties. This document is the property of IMEC vzw and by furnishing this information, IMEC vzw grants no license, express or implied under any patents, mask work rights, copyrights, trademarks, trade secrets or other intellectual property rights. IMEC vzw owns the copyrights of the information contained herein and gives consent for copies to be made of the information only for use within your organization with respect to "IMEC information". This consent does not extend to other copying such as copying for general distribution, advertising or promotional purposes, or for creating any work for release.

IMEC vzw shall not be held liable for any damages, which may result out of the use of IMEC information. Use of IMEC information implies the acceptance by user of all responsibility and liability connected with the use of IMEC information.